

The Zebbrace Micro is the perfect protector for small items such as microphones, guitar tuner, effect pedal, direct box, minidisk recorder, palm pilot and just about anything else that can benefit from impact and dust protection.

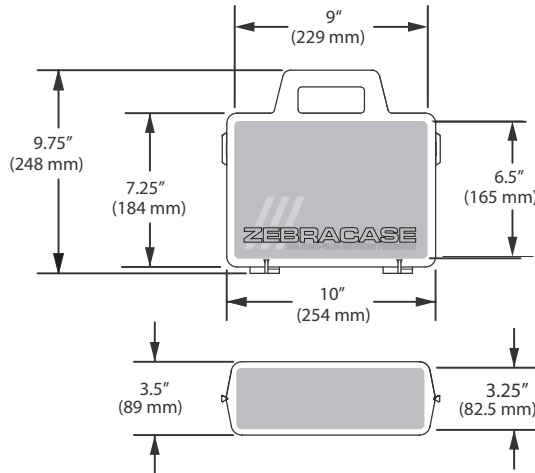

= Interior dimensions

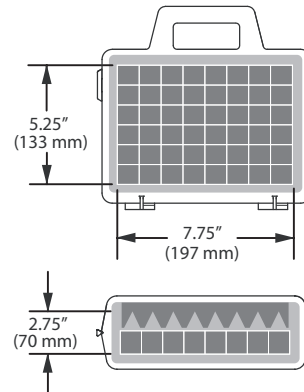

= Foam cradled dimensions

SPECIFICATIONS	Z9 Micro Order# Z100 0009
Case material	Polypropylene
Nominal shell thickness	.085"
Latches	Nylon
Mating joint type	Tongue & groove
Hinge pins	Stainless steel
Pick & protect foam	1.7 lb polyurethane
Temperate rating ⁽¹⁾ in storage	0°F (-18°C) to +120° F (+50°C)
Temperate rating ⁽²⁾ transport	10°F (-12°C) to +105° F (+40°C)
Temperate rating ⁽³⁾ drop	32°F (0°C) to +105° F (+40°C)
Standard Color	Black
Warranty:	3 years *

Temperature ratings: Zebbrace is well suited for term storage under severe⁽¹⁾ conditions. These case are designed to be used during normal ambient temperatures⁽²⁾ and are tested above freezing⁽³⁾ where plastics when left in sever cold can crack if subected to abuse. Zebbracases are desigend to work under these conditions and guaranteed to do so for 3 years.*See warranty information on the web site for complete details