

The Zebbracase Compact is the perfect protector for items such as a portable tape recorder, studio microphone, direct box, in-ear system, Walkman, GPS and just about anything else that can benefit from impact and dust protection.

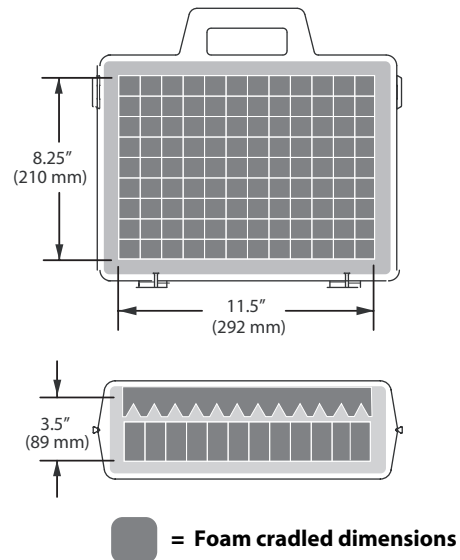
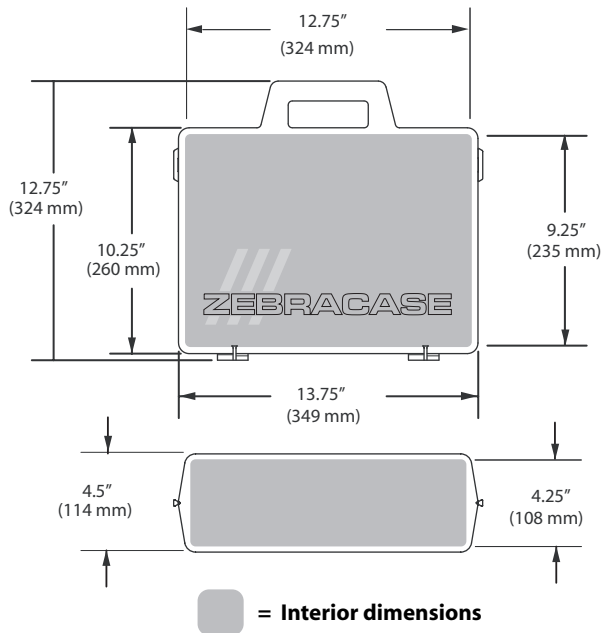

SPECIFICATIONS	Z15 Executive Order# Z100 0015
Case material	Polypropylene
Nominal shell thickness	.085" (2.16mm)
Latches	Nylon
Mating joint type	Tongue & groove
Hinge pins	Stainless steel
Pick & protect foam	1.7 lb polyurethane
Temperate rating ⁽¹⁾ in storage	0°F (-18°C) to +120° F (+50°C)
Temperate rating ⁽²⁾ transport	10°F (-12°C) to +105° F (+40°C)
Temperate rating ⁽³⁾ drop	32°F (0°C) to +105° F (+40°C)
Standard Color	Black
Warranty:	3 years *

Temperature ratings: Zebbracase is well suited for term storage under severe⁽¹⁾ conditions. These case are designed to be used during normal ambient temperatures⁽²⁾ and are tested above freezing⁽³⁾ where plastics when left in sever cold can crack if subected to abuse. Zebbracases are desigend to work under these conditions and guaranteed to do so for 3 years. *See warranty information on the web site for complete details